

VEGA ONE DESIGN ASSOCIATION (VODA)

Albin VEGA CLASS RULES 2006

I INTRODUCTION

These Albin VEGA Class Rules include the amended rules – which introduce a third class called “Touring Class”, but the rules for “Racing” and “Cruising Class” remain unchanged - as was decided by the VODA Meeting at Århus, Denmark, July 15th 2002, and confirmed at the VODA Meeting at Marstrand, Sweden, July 2004, (*see also Appendix 3*). Also, the redaction of some texts have been improved.

It was also decided at the last VODA Meeting 2004 , to skip the rule for the minimal engine weight of 120 kg, putting more emphasis on the requirements of measuring the “floating marks” under point III. F.

These Rules replace the rules adopted at Karlskrona July 5th, 1988, and those approved in Nov 1970 and revised at the VODA annual meetings in Dec. 1972 and Sept. 1975, known as "VEGA ENTYPREGEL 1976. RULES FOR THE VEGA CLASS".

The Rules stated here are valid for the Albin VEGA-cruiser, designed by Per Brohäll, and refer to all hulls that have been manufactured out of moulds that were made, directly or indirectly, from the original master plug.

In this document Albin VEGA will be abbreviated to VEGA.

II ADMINISTRATION

A. *International administration*

1. The VEGA One Design Rules are internationally administered by the VEGA One Design Association, "VODA", which is the international organisation for co-operation between the national VEGA associations.
2. VODA is the highest authority governing the VEGA CLASS RULES. A national VEGA association must not change the content of the Class Rules in any way that has significance for the issuing of a One Design Class Certificate. Temporary national exemptions and national limitations are allowed. Exemptions must be treated as stipulated below in chapter IV: Exemptions.
3. Proposals to changing any VEGA CLASS RULE should be directed to the VODA secretary in accordance with the statutes of VODA.
4. The official language of VODA is English. If questions of interpretation of these Rules arise the English text should be the deciding factor.
5. The Albin VEGA Class Rules can be downloaded from the VODA website.

B. National administration

1. The VEGA CLASS RULES are administered in the respective countries by the national VEGA Class organisations.
2. The national VEGA Class Organisation [*name*] in [*country*] ... is the official class organisation within [*country*]....
(*name and country to be entered by the resp. national Vega Class Organisation*)
3. Proposals to change any Class Rule must first be presented to VODA as stated in II.A.3. After adoption of the amendment by VODA each national VEGA Class organisation may decide to adopt the new Rule at its annual meeting or at an extra meeting announced at the annual meeting. The minimum number of participating class members at such a meeting to be a quorum is defined in the particular national Class Rules. The proposed changes must also be reported to the national official sailing organisation before they can come into force in the nation in question.
4. The boat owner is responsible for obtaining a Class Certificate.
5. After having his boat measured a Measurement Form in duplicate must be filled out and signed by the measurer and the owner. If the owner himself carried out this measurement, it should be witnessed and signed for by an other Vega Class Certificate holder, or 2 Vega owners being member of the Vega Class Organisation. One copy should be sent to the national VEGA Class Organisation, which after checking and approving the Form, will issue a Class Certificate. Permanent and time limited exemptions (see IV.A) must be noted in the Class Certificate. This Class Certificate, together with a valid edition of the VEGA CLASS RULES must be carried on-board when racing and these documents should be presented on request by any representative of the national VEGA Class organisation or official national sailing organisation or the organisation arranging the regatta.
6. The Class Certificate will be valid for four years at most. It should be checked every year by the owner concerning additions or modifications made to the boat, rigs or sails, which must if necessary be supported by measurements.
7. The boat owner has the responsibility to ensure that when racing his boat complies with the VEGA CLASS RULES and the Measurement Form.
8. Change of ownership will render the Class Certificate invalid. The new owner must obtain a new Class Certificate as described in II.B.4 and 6.
9. A National Class Organisation may establish an own procedure for obtaining a Class Certificate, provided it is in agreement with the spirit and purpose of aforesaid procedure. If so, VODA must be informed and must agree.

III MEASURING and MEASUREMENTS

A. General

1. Where not otherwise specified the IYRU measuring instructions must be applied.
2. Where it is not clearly stated that a measurement is delimiting (maximum or minimum) and where specific tolerances are not given, the following tolerances should apply:

<u>Measurement:</u>	<u>Tolerance:</u>
0 - 1000 mm	± 1.00 %
1001 - 3000 mm	± 0.50 %
> 3001 mm	± 0.25 %
3. The Measurement Form can be downloaded from the VEGA web site; alternatively, the national VEGA Class Organisation can provide such Form, translated or not.

B. *Hull, keel, rudder and deck with cockpit*

1. Hull, keel, deck, cockpit and cabin roof must be manufactured of glass fibre reinforced polyester (GRP). The rudder may be manufactured of any material.
2. Rudder, hull and keel must be made in forms and dimensions that were taken, directly or indirectly, from the master plug that was made by Larsson Trade Ltd for the first series of VEGA-cruisers. The deck, cabin roof and cockpit must have the same form as one of the models for the VEGA-cruiser that have been manufactured by Larsson Trade Ltd or Albin Marin Ltd. See also Drawing 4 for reference.
Therefore, no measurements will be taken of these components.

3. The following design specifications are valid:

Boat:

L.o.a.		8250 mm	± 15 mm
L.w.l.		7000 mm	no tolerance
Beam (max)		2460 mm	± 15 mm
Draft	min	1 170 mm	
Displacement	min	2300 kg	

keel ballast:

Lead		100 kg	± 4.0 %
Iron		740 kg	± 2.5 %
Polyester/sand		75 kg	± 4.0 %
Total		915 kg	± 25 kg

C. *Rig*

Rigging and spars must be in accordance with Drawing 2.

1. The mast
 - a. The mast must be made of aluminium alloy. The dimension of the mast profile must not be less than 135 x 95 mm and of uniform thickness and not tapered. The weight of the profile (without sail track, if this is not incorporated in the profile) must not be less than 2.5 kg/m.
The mast must be fitted with a track for mainsail slides or have this incorporated in the profile. The distance between the shroud and the mast side, measured along the spreader, must not be less than 755 mm.
The standing rigging must be in accordance with the drawing for measuring the rigging by Per Brohäll of Nov 10, corrected 24 Nov 1970 (see Drawing 2).
All shrouds and stays must be made of 1 x 19 stainless steel wire rope, minimum diameter to be 5 mm and must be fastened to the outer edge of the boat. An inner forestay must not be fitted. Internal halliards may be fitted in the mast.
 - b. The foot of the mast must not be moved from the place on the deck specified at manufacture. When producing new VEGA-cruisers or repairing old ones the distance from the forward side of the stem (without steel fitting) to the forward side of the mast must be 3100 mm.

- c. The mast must have two measurement bands. These must be black, 25 mm wide and painted on the mast; instead, adhesive black tapes are allowed.
The upper edge of the lower band must be located at least 1166 mm over the sheer line athwart ships of the mast (811+355 mm, see drawing in Appendix 2) or at least 811 mm over the lower end of the mast.
The lower edge of the upper band must be located at most 7900 mm above the upper edge of the lower band. (7900 mm = P = the distance between the two bands.)
 - d. The forestay, or the imaginary point of intersection between the forestay and the forward side of the mast should not be higher than 8273 mm above the upper edge of the lower band. (Max 1 = 9340 mm. See drawing in Appendix 2)
 - e. The distance from the lower end of the mast to the highest point of fastening the spinnaker pole or genoa pole to the mast should not exceed 2075 mm.
2. The main boom
- a. The main boom must be made of aluminium alloy and have a maximum profile height of 105 mm.
The length of the boom from the aft side of the mast to the outer end of boom must not exceed 3500 mm ± 50 mm.
The weight of the boom, including roller reefing gear and mast slide, must not be less than 6.75 kg.
 - b. The boom must be fitted with a measuring mark. The mark must be a black band, 25 mm wide and painted on the boom; instead, adhesive black tapes are allowed.
The distance from the aft side of the mast (i.e. from the bottom of the mast track profile or incorporated mast track) to the forward side of the measuring band must not exceed 3300 mm.
 - c. The sheeting of the main-sail and boom is optional.
 - d. The boom may be fitted with a kicking strap (a vang) or kick pole, the lower end of which must be attached to the mast step fitting or to the shroud chain plates.
3. The spinnaker pole and genoa pole, to be called pole.
- a. The mast must be equipped with one rail placed centrally and vertically on its forward side. The pole in use is only allowed to be fastened to a ring shaped device sliding along with this rail. For handling purposes 1 extra ring on said rail will be allowed.
 - b. The length of the pole measured, when it is set athwart ships and horizontally from the extreme outer end of the pole to the fore and aft centreline of the mast, must not exceed 3100 mm.

D. Sails

The number of measured and certified sails carried on board is optional; during racing other sails are not allowed on board.

Sails may be made of any material. Only rigid sails are not allowed.

The sails must be measured and marked as prescribed by the National VEGA Organisation. The measurements must be noted on the Measuring Form. The *LP*-measurement of the foresails must be written on the sails with water-resistant ink near and above the tack. See also Drawing 1.

When sails are measured they must be spread out on a flat surface and flattened, so that measurements can be taken without applying any tension on the sail cloth.

1. Mainsail

- a. The mainsail when hoisted must not be trimmed outside the inner edge of any measuring mark.
- b. The number and length of sail battens are optional.
- c. A mainsail should be measured at 1/4, 1/2 and 3/4 width along the leach, with measurements taken perpendicular to the luff. The horizontal width of the mainsail at 1/4 height must not exceed 2870 mm (0.87 *E* when *E* = 3300 mm), at 1/2 height must not exceed 2000 mm (0.60 *E*) and at 3/4 height 1120mm (0.34 *E*).
- d. The length of the headboard (measured horizontally) must not exceed 114 mm.
- e. The insignia on the mainsail must be shown on both sides, back to back, a black V-mark and a red 4-pointed star exactly as depicted in drawing 5. Also, the serial number of the yacht must be black and must be shown on both sides at different height below the V-mark. Preferably, the Starboard one higher than the Port one, unless the National Authority or IYRU racing rules have decreed otherwise.

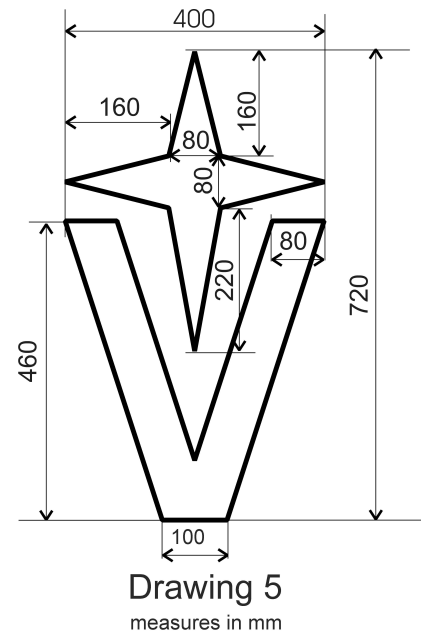

2. Jib and genoa

- a. The shortest distance from the clew (the theoretical point where the leach and the bottom meet) to the luff (*LP*) must not exceed 4650 mm.
- b. Battens are optional provided that:
 - (1) The length of battens must not exceed 248 mm (8% of *J*);
 - (2) The fore end of the battens must be forward of the centre line of the mast;
 - (3) 4 battens at most are used spaced evenly along the leach.
- c. The foresail must be sheeted to blocks fastened to the foot-rail on the outer edge of the deck. Sheeting of foresails through a block at the main boom end is not allowed.
- d. Two foresails may be sheeted to the same side only if one of the foresails is a spinnaker or a spinnaker-measured sail and the other is a jib or genoa.
- e. An arrangement to give the foresail an aerodynamically better fastening to the fore stay (e.g. head foil) is allowed only if it is an integral part of a roller arrangement for the foresail. When racing with such an arrangement the roller must not be dismantled.

3. Other foresails

a. Spinnaker

Equal measurement of luff/leach max 9340 mm

Foot (= greatest width) max 5580 mm

The width of the spinnaker at its half height (mid girth) must not be less than 75% of the foot (shortest distance between tack and clew). Luff and leach must be of equal length and the sail must be symmetrical, taken from a line from the head to the centre of the foot.

b. Gennaker

If in accordance with maximum dimensions as above with a mid girth not be less than 50% of the foot, the sail must be measured and sheeted as spinnaker. If the mid girth is less than 50% of the foot the sail must be measured (*LP* max 4650 mm) and sheeted as a genoa.

E. Accommodation arrangements and hull reinforcement

The accommodation arrangement of the yacht must be fitted according to interior drawing “(Larsson Trade AB) 1968-08-26 No LT- 153” in Drawing 4, VEGA Cross-cut, allowing for minor alterations made by subsequent makers. The accommodation and fittings may be changed for convenience but must not be altered in such a way that the weight is concentrated amid ships. Reinforcements of the hull, mast beam etc. are allowed.

F. Weight

1. The weight of a yacht ready to race must not be less than 2300 kg.

2. Checking of weight

a. It is not necessary to weigh the boat. Instead the weight can be checked with the help of the floating marks. The nominal displacement with the boat floating just on the marks is 2300 kg.

b. The floating marks are two screws.

The Forward one, 1116 mm from the sheer line measured along the stem.

The Aft One 350 mm from the lowest point of the transom measured forward along the hull on the centre line.

3. Only equipment to be on board when the weight is checked:

When checking the floating trim (displacement) the boat must be normally equipped for racing but must not have any crew on board, nor any edible supplies and clothes. This means that the boat must be completely rigged and have on board all sails normally used when racing. Also equipment for navigation, cooking, anchoring and mooring, 1 or 2 batteries having a nominal capacity of at least 40 Ah and safety equipment must be on board. Water and fuel tanks and any sump tanks must be almost empty (i.e. not filled to more than a quarter of their original capacity).

4. Weight checking procedure.

With the equipment listed above, the boat must be trimmed so that it floats parallel to the floating marks and does not heel. The marks must then appear in or below the water surface.

5. If the boat floats above the floating marks she must be weighed down, in accordance to point G.

The location(s) of this extra weight (if any) should be fixed and should not be changed during racing. This weight and its location(s) should be noted on the Measurement Form. The floating marks checking procedure may be replaced with checking by means of two measuring chains. See APPENDIX 2 and Drawing 3.

6. After the weight has been checked and approved, further loose items must be stowed on board during racing; their location onboard is optional.

G. *Athwart ships stability*

1. A properly fitted-out yacht in racing trim should have an initial athwart ship stability of not more than 520 Nm (53 kpm) for 1° of heel.
2. If there are any doubts of a yacht being favoured in this respect due to any reason, a stability test may be requested to be carried out only by entitled members of a VEGA Class Organisation.
3. The owner of the boat in question is liable to have his boat tested.
4. During the checking of the athwart ships stability the yacht must be trimmed as described in point II.F.4, provided that a spinnaker pole may be used for the test procedure.
5. The measuring procedure is described in APPENDIX 1

H. *Engine and propeller*

- a. The yacht must have a permanently installed inboard engine.
- b. The engine must always be positioned inside the box designed for it.
- c. The propeller may have feathering, folding or fixed blades.
- d. With the engine the boat running must be able to attain a speed of 5 knots.

I. *Safety equipment and navigational aids*

1. There must be at least one guard rail at each side of the boat at a height of at least 300 mm above the deck
The guard rails wires need not to be fixed to the aft stanchion of the pulpit, but the height of the guard rail at this point must not be less than 100 mm above the deck.
2. Safety equipment must be carried in accordance with valid racing rules. If a liferaft is carried, it must be located on deck or in the cockpit.
3. Radio and electronic aids may be used in accordance with local racing rules.

IV EXEMPTIONS

A. *Definitions*

1. Exemptions can be permanent, time-limited or temporary.
2. An exemption may be issued by the national VEGA class organisation ("the VEGA Committee") to a particular owner for his VEGA if the yacht has a valid Class Certificate in all other respects.
3. Permanent exemptions should not be issued without prior consultation of VODA in order that such exemptions can be co-ordinated internationally.

B. *Permanent exemptions* may be issued to yachts that already have exemptions under the Rules for the VEGA class 1976 concerning divergent masts supplied not later than 28th Oct, 1970.

C. *National racing.* *See Appendix 3 for admitting different Racing Classes*

1. Time-limited exemptions may be issued for a certain period (usually one sailing season), if "the VEGA Committee" considers that the deviation from the Rule does not give undue advantage to the yacht when she is racing. After the test period, during which the exemption is valid, the time-limited exemption will either be converted to a permanent one or will automatically become invalid.
2. Temporary exemptions may be issued by 'the VEGA Committee' - or this authority may be delegated to the sailing committee of a certain regatta or series - to VEGA cruisers taking part in the particular regatta or series, if the committee considers that the deviation from the Rule does not give undue advantage to the yacht when racing.

D. *International racing.* *See Appendix 3 for admitting different Racing Classes.*

Temporary exemptions may be issued at international VEGA One Design Class racing (e.g. VEGA International Friendship Regatta's) by the Racing Officer on recommendation from a measuring committee that has been elected for the occasion and consists of representatives of all participating nations. Information about such exemptions should be made available to the skippers of the VEGA's before the start of the Regatta.

APPENDIX 1, *Athwart Ships Stability* (to paragraph III.G.5)

Athwart ships stability: Measuring procedure

1. The intention of the measuring procedure described below is to ascertain that the athwart ships stability will not be more than 520 Nm (53 kgm) for 1° of heel.
2. Equipment for the measuring should be a spinnaker pole according to III C.3.b, a container with a screw lid (or a bucket) and a lanyard to fasten it to the pole, a transparent hose with an inside diameter of at least 12 mm and a supply of water.
3. Measuring procedure:
 - a. The hose should be attached to the main shrouds, so that the distance between the centres of the hose ends should be 2450 mm at a height of about 0.5 m above the cabin roof. The middle of the hose rests on the cabin roof. The hose should be filled with water to a level of about 0.2 m below each end of the hose. At each end of the hose, a scale (or a measuring tape) should be fastened along it, so that the different water levels can be read (or marked).
 - b. On the pole that is to be used, make a mark 3000 mm from the centre of the mast, when one end of the pole is attached to the mast and swung out horizontally and then tied to the forward side of the main shroud.
 - c. The pole must be weighed and a weight "W" must be calculated so that $W = 15 \text{ kg}$ minus half of the pole weight.
 - d. The container and the lanyard should be placed on a set of scales and the container should then be filled with water until the total weight is $W \pm 50 \text{ g}$.
 - e. The pole should be positioned between the main shroud and the forward lower shroud on one side and attached to the mast. It should then be lifted to a horizontal position and at that point tied to the main shroud.
 - f. The 'W weight' (container and lanyard) should be attached to the pole at the 3000 mm mark.
 - g. The water level in the hose should be read in mm (marked on the tape).
 - h. The "W weight" should be removed.
 - i. The water level in the hose should be read in mm (marked on the tape. This will be the check mark).
 - j. The procedure must be repeated on the other side.
4. Measuring result:

The distance between the upper and lower water levels in the hose on the respective sides after measured as described above must not be less than 16 mm.

APPENDIX 2 (to paragraph III.F.6)

Alternative floating check of the VEGA (see Drawing 3)

This method is suitable to be applied to a VEGA on which the original “floating marks” have disappeared or are invisible, particularly at the stern. Two thin chains will be required, each lengthened by a cord so that they can be tied to the pushpit and pulpit respectively. These will be kept by the Racing Committee.

At the stem end, from the highest point of the Bow (deck not included), hang down a chain 918 mm long \pm 3mm.

At the stern, from the highest point of the transom (deck not included), precisely on the centre line, hang down a chain of 752 mm long \pm 3 mm.

Measuring condition of the boat. To be equipped in accordance with paragraph III.F.3 and trimmed according to paragraph III.F.4 –5 so that she floats parallel to the loose ends of the chains.

Check by looking at the loose ends of the chains after having left the boat. These should be submerged or touching the water simultaneously.

APPENDIX 3, Racing Classes (to I, INTRODUCTION and IV, EXEMPTIONS C and D)

Racing practice with the VEGA in different Racing Classes

1. In the course of years the need for different classes has arisen. This allows VEGA sailors without a spinnaker, or those who have an un-measured boat, to sail within separate classes. There are already two classes which have emerged for the measured boats meeting the Vega One Design Rules. They are the Racing Class (with spinnaker) and the Cruising Class (without spinnaker or similar). At the VODA General meeting on Monday 15th July 2002, a proposal was accepted to introduce a third class for all VEGA's that do not meet the VEGA Class Rules.
2. Racing Classes that are known and accepted by the VODA:
 - a. VEGA Racing Class
All boats in the Racing Class will need to be standard VEGA One Design boats, which have met all the VEGA Class Rules in all respects (as required by the measurement form: to be measured and controlled by the local VEGA-organisation). The Racing Class will sail with spinnaker.
 - b. VEGA Cruising Class
All boats in the Cruising Class will need to be standard VEGA One Design boats, which have met all the VEGA Class Rules in all respects (as required by the measurement form: to be measured and checked by the local Vega-organisation). In the Cruising Class spinnaker and gennaker are not allowed.
 - c. VEGA Touring Class
The Touring Class is for all other boats not meeting the VEGA Class Rules. Allowed sails during racing in a specific regatta will be determined by the national VEGA Class Organisation supervising that regatta.
 - d. Remark. The number of Classes that will sail at a specific regatta may be less than 3, and will be decided by the national VEGA Class Organisation supervising that regatta.

SEGEL/Sail	LIK LÄNGD m.m. / Length			DUKVIKT Weight GR/M ²	VERKLYTA Real area M ²	ANM. Notes
	FÖR Luff	AKTER Leach	UNDER Foot			
STORSEGEL Main sail	7900 25' 11"	8460 ¹⁾ 27' 8 3/4"	3300 10' 10"	250 MIR	14,8 15,9 #	1/2 RUNDA/Round 300 LATTOR/Battens 630 & 700
LÄTTVINDSGENUA Light genoa	9400 30' 10"	9120 29' 11"	4900 ²⁾ 16' 3/8"	170	22,6 24,3 #	3/4 RUNDA/Round 250
STANDARD GENUA Gen. purpose genoa	9250 30' 4 1/2"	8700 28' 6 1/2"	4650 15' 3"	230	19,7 21,2 #	
FOCK NR. 1 Jib	8400 27' 6 3/4"	7340 24' 1 3/8"	3700 12' 1 3/4"	250	13,5 14,5 #	STROPP 0,9M Pennant 3'
FOCK NR. 2 Jib	7100 23' 3 1/2"	5800 19' 3/8"	3150 10' 4"	250	8,9 9,6 #	STROPP 2,25M Pennant 7' 5"
FOCK NR. 3 Jib	5700 31' 2"	4280 26' 3"	2640 18' 1/2"	250	5,4 5,8 #	STROPP 3,6M Pennant 11' 10"
DRIFTER	9500 31' 2"	8000 26' 3"	5500 ²⁾ 18' 1/2"	110	23,0 24,8 #	UTAN HAKAR Set flying
STANDARD SPINNAKER Gen. purpose	MAX. LIKLÄNGD Luff/Leach 9340 30' 8 3/4"	MAX. BREDD Mast 5500 18' 3 3/8"		50	~47 50,6 #	STANDARD LIKL 9220/30' 3" LÄTT/Light 271/2"

Drawing 1, Sail Plan
(to paragraph III D. of Vega Class Rules 2006)

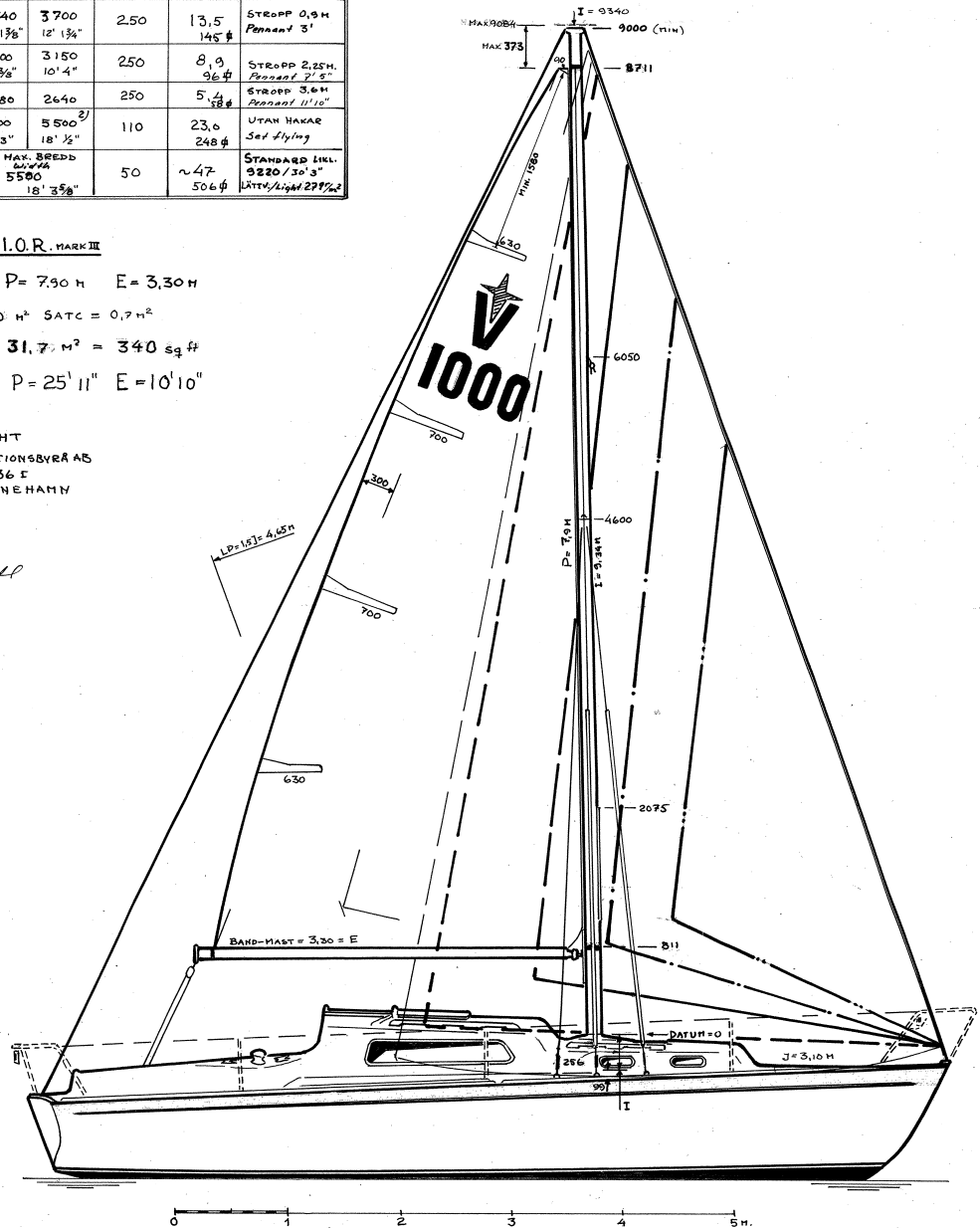

SEGELMÄTNING ENLIGT I.O.R. MARK III

I = 9,34 m. J = 3,10 m P = 7,30 m E = 3,30 m
 R_{SAF} = 21,0 m² R_{SAH} = 10,0 m² S_{ATC} = 0,7 m²
 R_{SAT} = HÄTT SEGELYTA = 31,7 m² = 340 sq ft
 I = 30' 7 3/4" J = 10' 2" P = 25' 11" E = 10' 10"

COPYRIGHT
 BRONHÄLLS KONSTRUKTIONSBYRÅ AB
 ÅKERVÄGEN 36 F
 68100 KRISTINEHAMN

29/11 1969
 P. Bronhäll

REV. BSAT, FOKER 3 9/1972 22. REV. ENL. VEGA O.D.A.S. 13/1 1970 23. 59-4:5

2-3950 026

Drawing 2, Rigging

to paragraph III.C. of Vega Class Rules 2006

10/11 1970
 P. Bröskvall
 15/4-76 P.B.
 KORR. 24/11-70 P.B.

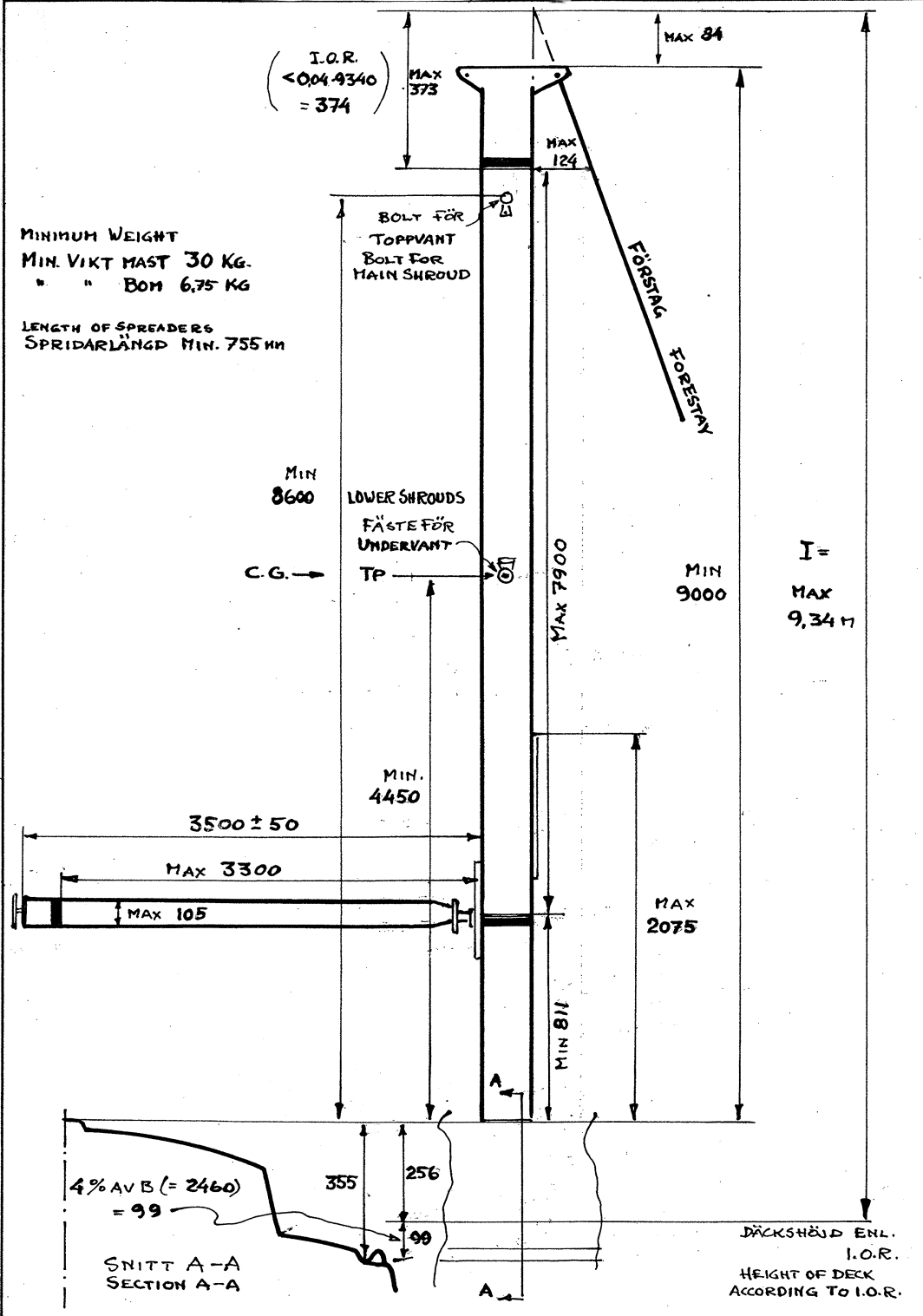

113 A4
 SIS 73 25 01
 ESSELTE
 4401

Copyright Sveriges Standardiseringskommission

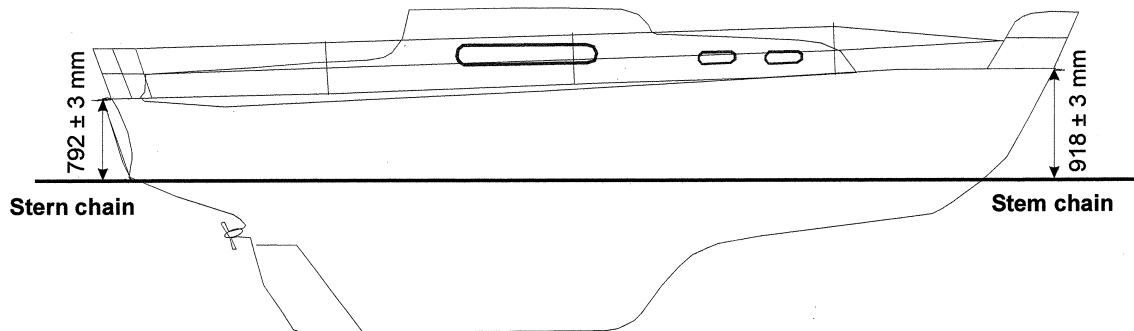

Drawing 3, alternative floating measurement
 (to paragraph III.F.6 and Appendix 2 of Vega Class Rules 2006)

Date 17-01-2006
 JW

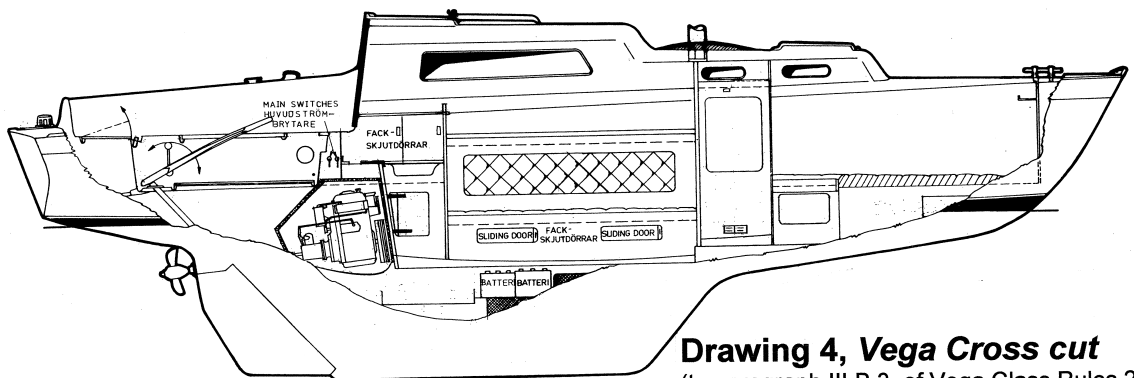

Drawing 4, Vega Cross cut
 (to paragraph III.B.3. of Vega Class Rules 2006)

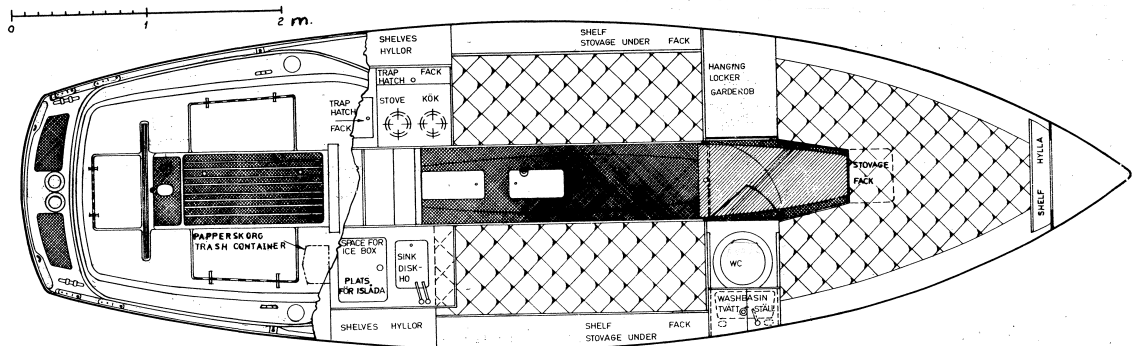

VEGA
 INREDNINGSRITNING

DAT 74-10-03
 3-56239

Rev. 01. -77/EKT